

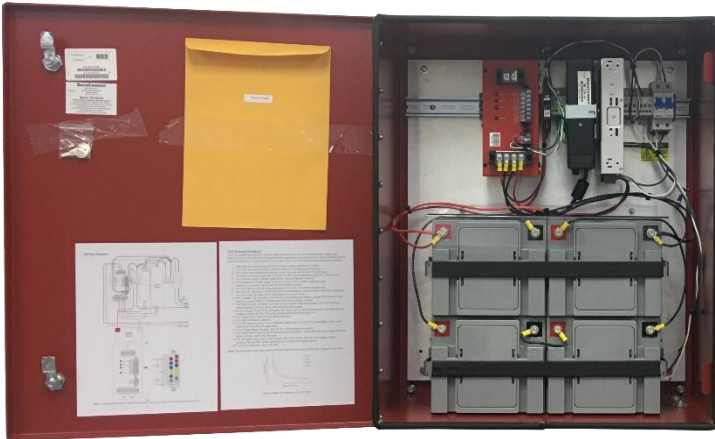

# PS-548-50

## Public Safety Power Supply and Battery Backup System



- *NFPA 1221 Compliant AC Power Supply and Battery Backup System*
- *NEMA 4X Enclosure with Top and Bottom Mounting Flanges*
- *Auto-Ranging Input Voltage 90 – 264 VAC*
- *Form C Relay Alarm Outputs*
- *Internal Alarm Status LEDs for Charger Fail, Battery Low, and AC Fail*
- *AC Input and Battery Breakers Included*
- *Low Voltage Disconnect*
- *3-Stage Smart Battery Charger*

Model	PS-548-50
Output Voltage	56 VDC
Output Amperage	5 Amps Max
Maximum Power	300 Watts
Maximum Ripple and Noise	250 mV p-p
Voltage Tolerance	± 1.0 %
Line/Load Regulation	± 0.2 % / ± 0.5 %
AC Input	90 - 264 VAC auto-ranging, 47 - 63 Hz
Typical Efficiency	89 %
Maximum AC Current	6.5A/115VAC, 3.3A/230VAC, two 10A breakers
Max Inrush Current, single cycle	35A/115VAC, 70A/230VAC
Short Circuit Protection	Constant Current Limiting
Overload Protection	105 - 135 % rated output power
Over Voltage Protection	57.6 - 67.2 VDC
Over Temperature Protection	Auto Output Shutdown > 195 F (90 C)
Working Temperature Range	-4 to 122 F (-20 C to 50 C)
Storage Temperature Range	-40 to 185 F (-40 C to 85 C)
Withstand Voltage	I/P-O/P: 3KVAC, I/P-FG: 2KVAC, O/P-FG: 0.5KVAC
Battery Charger Output	55.2 VDC / 4 Amps Max
Max Battery Charger Power	230 Watts
Auto-Revert Battery / Power Supply	By dual Schottky diodes in OR configuration
Battery	4, AGM, 12V, 50AH each
Battery Bank	50 Amp-Hour
Maximum Continuous Battery Current	20 Amps, one 20A breaker
Load Disconnect / Reconnect	40 / 50 VDC (approx. 2 minutes disconnect delay)
Charger Fail Alarm Relay	50 VDC Alarm, 52 VDC Reset, Form C Contacts
Battery Low Alarm Relay	46 VDC Alarm, 50 VDC Reset, Form C Contacts
AC Fail Alarm Relay	AC OFF Alarm, AC ON Reset, Form C Contacts
Product Dimensions	30 x 23 x 12 in
Shipping Dimensions / Weight	31 x 30 x 17 in / approx. 185 lbs.

\*NOTE: Specifications are subject to change without notice.

## Section 1 | Important Safety Instructions

THESE INSTRUCTIONS ARE INTENDED FOR USE BY A TECHNICIAN FAMILIAR WITH ELECTRONIC PRODUCTS.

**WARNING:** There are no user serviceable parts inside. High voltage may be present. Service must be referred to a qualified factory personnel.

**NOTE:** The individual user should take care to determine prior to use or installation whether this device is suitable, adequate, and safe for the use intended. Since individual applications are subject to numerous variations, DuraComm makes no representation or warranty as to the merchantability, suitability, or fitness of these units for any specific application.

## Section 2 | Product Overview

The public safety PS Series is a NFPA 1221 compliant power supply and battery backup system housed in a weather-proof 0.125" aluminum NEMA 4X enclosure. The system includes a 300-Watt power supply, a 3-stage smart battery charger, a backup battery bank, low voltage disconnect, and internal alarm LEDs for charger fail, battery low, and AC fail with form C relay outputs. See [www.duracomm.com](http://www.duracomm.com) for more information.

## Section 3 | Installation and Testing

### Conductor Pretreatment

All kinds of copper conductors can be clamped without treatment. DO NOT solder tin stranded conductors. The solder yields and fractures under high pressure. The result is increased contact resistance and excessive temperature rise. Additionally, corrosion has been observed due to the fluxes. Notch fractures at the transition from the rigid tinned part to the flexible conductors are also possible. Ferrules can be used as a protection when wiring stranded conductors. Copper ferrules prevent the current transfer from being influenced by dissimilar metals and remove the risk of corrosion. Always use the correct tool to crimp the ferrule.

### Recommended Copper Wire Size for Current Capacity

(Insulated Wire, Single Conductor in free air)

Current Level in Amperes	Wire Size Requirements According to MIL-W-5088B	
	Up to 5 feet	Up to 10 feet
<7 AMPERES	20 AWG	18 AWG
14 AMPERES	18 AWG	16 AWG
20 AMPERES	16 AWG	14 AWG
30 AMPERES	14 AWG	12 AWG
40 AMPERES	12 AWG	10 AWG
50 AMPERES	10 AWG	8 AWG
70 AMPERES	8 AWG	6 AWG
100 AMPERES	6 AWG	4 AWG

### Wire Installation Procedure

1. Turn OFF the AC and battery breakers in the PS Series Power Supply and Backup System.
2. Connect the PS Series Power Supply and Backup System to the external AC power.
3. Connect the equipment to the "Load" terminal on the DAL red alarm box.
4. Apply external AC power to the PS Series Power Supply and Backup System.
5. Turn ON the AC Line and Neutral breakers, then turn ON the battery breaker.

# Wiring Diagram

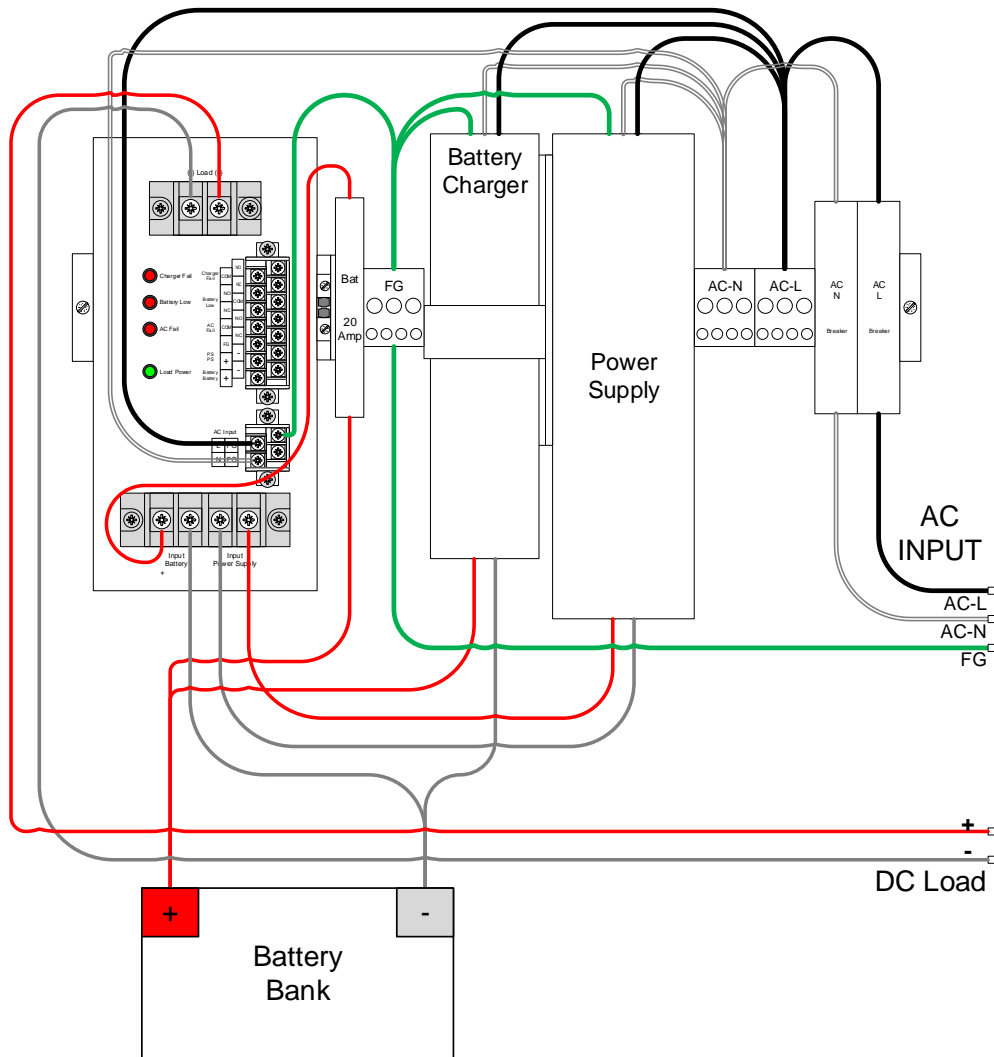

(a)

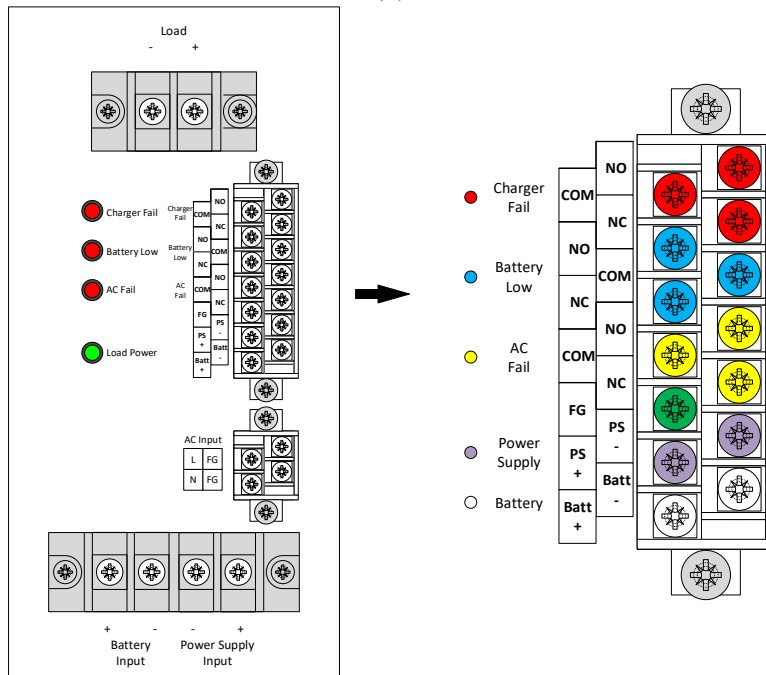

(b)

Figure 1. (a) Diagram for the AC and DC connections. (b) Form C alarm connections on the alarm box.

## Full Testing Procedure

This is a manual procedure to test the battery backup time for the PS Series Power Supply and Backup System. The user may arrange for other equipment and procedures to log the timeline of the events in this test. This test assumes the system under test has been properly wired and installed.

1. Open the front door of the PS-548-50 Power Supply and Backup System.
2. Turn OFF the battery breaker, and then the AC Line and Neutral breakers.
3. Disconnect the equipment from the “Load” terminal on the DAL red alarm box.
4. Connect an external test load of 2 Amps to the “Load” terminal on the DAL red alarm box.
5. Turn ON the battery breaker, and the AC Line and Neutral breakers.
6. Use a clamp-on current meter to verify 2 Amps of DC current to the test load.
7. Prepare to manually log the time of the following events.
8. Turn OFF the AC Line and Neutral breakers but leave the battery breaker ON.
9. The “AC Fail” red alarm LED should turn on immediately, and the battery should be supplying current to the test load. Verify with clamp-on current meter.
10. The “Charger Fail” red alarm LED should come on next as battery voltage falls below 50 VDC (with an approximately 2-minute delay after reaching the voltage).
11. The “Battery Low” red alarm LED will come on when battery discharge to 46 VDC (with an approximately 2-minute delay after reaching the voltage).
12. As the voltage continues to decrease, the battery will be disconnected from the load when its voltage reaches 40 VDC. The load voltage and current will drop to 0.
13. The “Load Power” LED will turn off at this point.
14. Turn OFF the battery breaker.
15. Turn OFF and disconnect the 2-Amp test load, then re-connect the equipment to the “Load” terminal on the DAL red alarm box.
16. Turn ON the battery breaker, and the AC Line and Neutral breakers.
17. The “Load Power” green LED should turn on immediately. Verify that the power supply and the battery charger are in the ON state.
18. The red alarm LEDs should start to turn off in the reverse order as the battery voltage increase. Please refer to the specifications for recovery voltage levels.
19. The test is complete. Close the door.

**Note:** The discharge cycle takes about 24 hours (new 50-AH battery bank and 2-Amp DC test load).

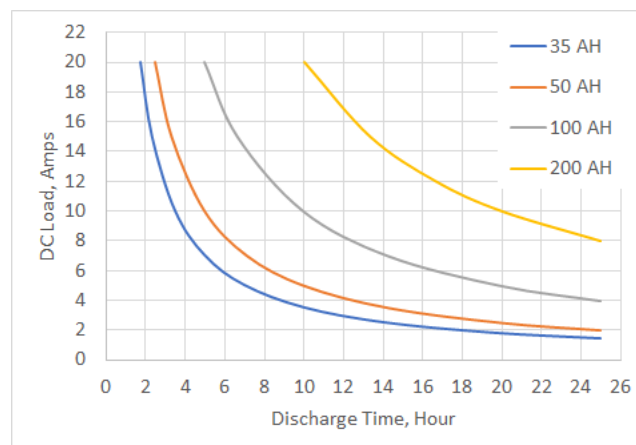

Figure 2. Battery discharging curve at 20°C (68°F).

## Section 4 | Warranty

*DuraComm warrants to the initial end user, each power supply manufactured by DuraComm to be free from defects in material and workmanship when in normal use and service for a period of three years from the date of purchase from an authorized DuraComm dealer.*

*Should a product manufactured by DuraComm fail or malfunction due to manufacturing defect, or faulty component, DuraComm, at its option, will repair or replace the faulty product or parts thereof, which, after examination by DuraComm, prove to be defective or not operational according to specifications in effect at the time of sale to the initial end user. The product that is replaced or repaired under the provisions of this warranty will be warranted for the remainder of the original warranty period, only, and will not extend into a new three-year warranty period.*

*The limited warranty does not extend to any DuraComm product which has been subject to misuse, accidental damage, neglect, incorrect wiring not associated with the manufacturer, improper charging voltages, or any product which has had the serial number removed, altered, defaced, or changed in any way.*

*DuraComm reserves the right to change, alter, or improve the specifications of its products at any time, and by so doing, incurs no obligation to install or retrofit any such changes or improvements in or on products manufactured prior to inclusion of such changes.*

*DuraComm requires any product needing in or out of warranty service to be returned to DuraComm. All requests for warranty service must be accompanied by proof of purchase, such as a bill of sale with purchase date identified. DuraComm is not responsible for any expenses or payments incurred for the removal of the product from its place of use, transportation or shipping expenses to the place of repair, or return expenses of a repaired or replacement product to its place of use.*

*The implied warranties that the law imposes on the sale of this product are expressly LIMITED, in duration, to the three (3) year time period specified herein. DuraComm will not be liable for damages, consequential or otherwise, resulting from the use and operation of this product, or from the breach of this LIMITED WARRANTY.*

*Some states do not allow limitations on the duration of the implied warranty or exclusions or limitations of incidental or consequential damages, so said limitations or exclusions may not apply to you. This warranty gives you specific legal rights which vary from state to state.*

*This warranty is given in lieu of all other warranties, whether expressed, implied, or by law. All other warranties, including WITHOUT LIMITATION, warranties of merchantability and fitness or suitability for a particular purpose, are specifically excluded. DuraComm reserves the right to change or modify its warranty and service programs without prior notice.*

## Section 5 | Contact Us

### Location

6655 Troost Avenue  
Kansas City, MO. 64131

### Phone Numbers:

816-472-5544  
800-467-6741

### Fax Number:

816-472-0959

### Email Purchase Orders to

[order@duracomm.com](mailto:order@duracomm.com)

[www.DuraComm.com](http://www.DuraComm.com)

