



A Benny Lee Company

PRODUCT USER GUIDE

RMBC & RMBB Battery Backup Modules Owners Guide

(These instructions are intended for use by a technician familiar with electronic products)

- RMBC, and RMBB are designed to custom mount on the rear panel of RM Series power supplies to provide a solid state battery backup system
- Dual Shottky Diodes provide protective isolation and seamless transfer to battery when power goes down
- RMBC provides dual diode isolation and float charge battery maintenance
- RMBB provides dual diode isolation without battery charging.
- 3 year warranty



DESCRIPTION

RMBC and RMBB combine with RM series power supplies to provide solid state battery backup operation. They can handle up to 75 amps continuous and up to 60 VDC input. RMBC and RMBB are automatically provides float charge, battery maintenance when power is restored.

SPECIFICATIONS

Input Voltage Range	Up to 60 VDC RMBC & RMBB
Current Capacity	75 Amps RMBC & RMBB
Output Voltage to Load @ 13.8 VDC Input.....	13.4 VDC RMBC & RMBB
Output Current to Battery @ 13.8 VDC Input	1 - 3 Amps Prox RMBC
Output Voltage to Load @ 27.5 VDC Input.....	27.0 VDC RMBC & RMBB
Output Current to Battery @ 27.5 VDC Input	1 - 3 Amps RMBC
Output Voltage to Load @ 55.2 VDC Input.....	54.9 RMBC & RMBB
Output Current to Battery @ 55.2 VDC Input	1 -2 Amps Prox RMBC
Isolation	Heavy Duty Schottky Diodes RMBC & RMBB
Size	5.62" W x 3.65" x 4.0" D

INSTALLATION WARNING

NOTE: The individual user should take care to determine, prior to use or installation, whether this device is suitable, adequate or safe for the use intended. Since individual applications are subject to great variation, DuraComm makes no representation or warranty as to the suitability, or fitness of these units for any specific application.

PRECAUTIONS: Be certain to locate the battery in a ventilated area. During recharging, small quantities of hydrogen gas may be produced. Hydrogen gas is highly flammable and under the right conditions, explosive.

INSTALLATION

Remove the 4 screws from the back of the RM power supply as indicated in figures 2. Keep 2 of these screws to fasten the top on the RMBC.

INSTALLATION BLOCK DIAGRAM

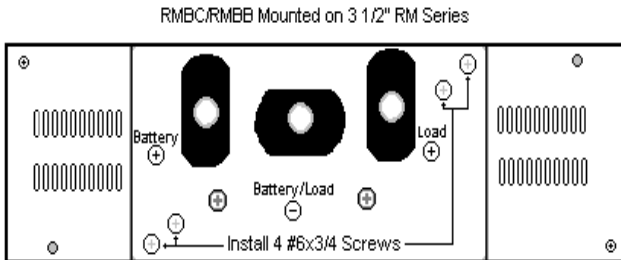

This system setup using a RMBC, will provide battery float charging when the AC power is on, and a seamless transfer of the load to the battery when the AC power goes down.

Wire according to the diagram shown in Figure 3, carefully observing polarity, and using wire large enough for the amperage capacity of your system. RMBC input and output terminals will accept parallel #10 AWG, or up to single #4 AWG. (See wire chart on page 4 for guidelines)

NOTE: The RMBC internal charge controlling resistor values, (1 ohm 30 watt) are based on using a 100 Ah deep cycle marine type battery. If a different type of battery is used, the float charge current must be measured and the values of the resistors adjusted to provide a float charge rate equal to 1-2% of the battery Ah capacity.

RMBB

Wire according to the diagram shown in Figure 4, carefully observing polarity, and using wire large enough for the amperage capacity of your system. RMBB input and output terminals will accept parallel #10 AWG, or up to single #4 AWG. (See wire chart on page 5 for guidelines.)

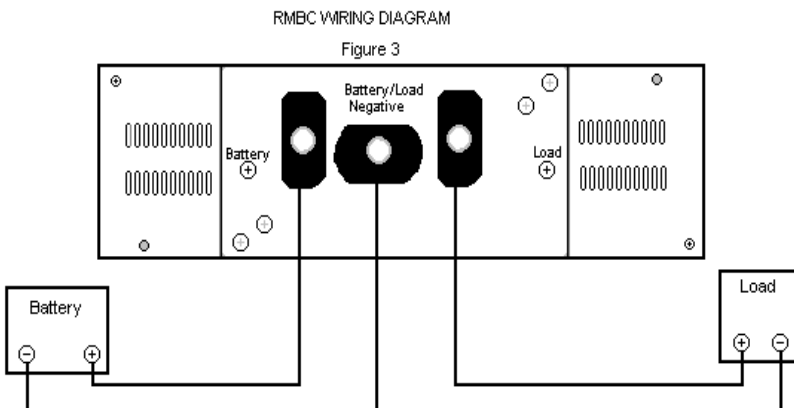

RMBB WIRING LAYOUT

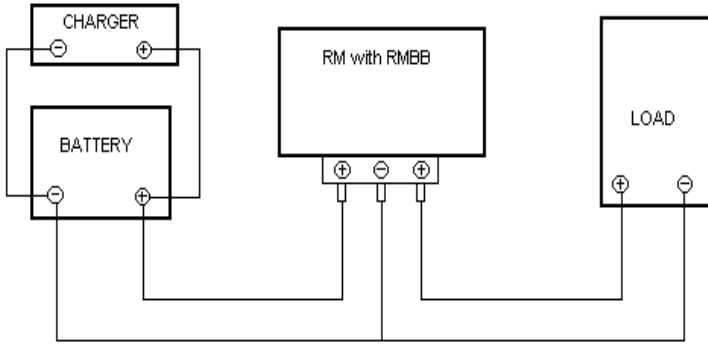

Figure 4

NOTE: As the RMBB does not provide charging voltage for the battery, from the primary power supply, a separate source of battery charging must be used. Because of the diode switching system used in the RMBB, **the voltage output of the charger must be at least 0.4 volts less than the voltage output of the primary system power supply.** If this is not done, the charger will attempt to supply the entire system load.

In addition, the charger should be well regulated and filtered to provide pure DC. Typical automotive type battery chargers often put out pulsed DC at 20 volts or more, which may be harmful to communications equipment. **They should not be used.**

CONDUCTOR PRETREATMENT

All kinds of copper conductors can be clamped without treatment. DO NOT solder tin stranded conductors. The solder yields and fractures under high pressure. The result is increased contact resistance and excessive temperature rise. Additionally, corrosion has been observed due to the fluxes. Notch fractures at the transition from the rigid tinned part to the flexible conductors are also possible. Ferrules can be used as a protection when wiring stranded conductors. Copper ferrules prevent the current transfer from being influenced by dissimilar metals and remove the risk of corrosion. Always use the correct tool to crimp the ferrule.

RECOMMENDED COPPER WIRE SIZE FOR CURRENT CAPACITY

(Insulated Wire, Single Conductor in free air)

<u>Current Level in Amperes</u>	<u>Wire Size</u>
<7 AMPERES	20 AWG Up to 5 feet 18 AWG Up to 10 feet
14 AMPERES	18 AWG Up to 5 feet 16 AWG Up to 10 feet
20 AMPERES	16 AWG Up to 5 feet 14 AWG Up to 10 feet
30 AMPERES	14 AWG Up to 5 feet 12 AWG Up to 10 feet
40 AMPERES	12 AWG Up to 5 feet 10 AWG Up to 10 feet
50 AMPERES	10 AWG Up to 5 feet 8 AWG Up to 10 feet
70 AMPERES	8 AWG Up to 5 feet 6 AWG Up to 10 feet
100 AMPERES	6 AWG Up to 5 feet 4 AWG Up to 10 feet

LIMITED WARRANTY

DuraComm warrants to the initial end user, each power supply manufactured by DuraComm to be free from defects in material and workmanship, when in normal use and service for a period of three year from the date of purchase, from an authorized DuraComm dealer.

Should a product manufactured by DuraComm fail or malfunction due to manufacturing defect, or faulty component, DuraComm, at its option, will repair or replace the faulty product or parts thereof, which, after examination by DuraComm, prove to be defective or not operational according to specifications in effect at the time of sale to the initial end user. The product that is replaced or repaired under the provisions of this warranty, will be warranted for the remainder of the original warranty period, only, and will not extend into a new three year warranty period.

The limited warranty does not extend to any DuraComm product which has been subject to misuse, accidental damage, neglect, incorrect wiring not associated with manufacture, improper charging voltages, or any product which has had the serial number removed, altered, defaced, or changed in any way.

DuraComm reserves the right to change, alter, or improve the specifications of its products at any time, and by so doing, incurs no obligation to install or retrofit any such changes or improvements in or on products manufactured prior to inclusion of such changes.

DuraComm requires any product needing in or out of warranty service to be returned to DuraComm. All requests for warranty service must be accompanied by proof of purchase, such as bill of sale with purchase date identified. DuraComm is not responsible for any expenses or payments incurred for the removal of the product from its place of use, transportation or shipping expenses to the place of repair, or return expenses of a repaired or replacement product to its place of use.

The implied warranties which the law imposes on the sale of this product are expressly LIMITED, in duration, to the three (3) year time period specified herein. DuraComm will not be liable for damages, consequential or otherwise, resulting from the use and operation of this product, or from the breach of this LIMITED WARRANTY.

Some states do not allow limitations on the duration of the implied warranty or exclusions or limitations of incidental or consequential damages, so said limitations or exclusions may not apply to you. This warranty gives you specific legal rights which vary from state to state.

This warranty is given in lieu of all other warranties, whether expressed, implied, or by law. All other warranties, including WITHOUT LIMITATION, warranties of merchantability and fitness or suitability for a particular purpose, are specifically excluded. DuraComm reserves the right to change or modify its warranty and service programs without prior notice.

DuraComm® Corporation

6655 Troost Avenue
Kansas City, MO 64131
Phone (816) 472-5544 Fax (816) 472-0959
www.duracomm.com