



A Benny Lee Company

# PRODUCT USER GUIDE

## RLP-4012-BBSCLVD

### Heavy Duty AC to DC Power Supply Owners Guide

*(These instructions are intended for use by a technician familiar with electronic products)*

- Power Factor Correction
- Selectable Input Voltage 110 or 220 VAC
- Metering: Voltage / Amperage
- Remote control / Remote Sense
- DC-OK TTL signal
- Short Circuit / Overload / Over Voltage / Over Temperature Protection
- Manual Battery Disconnect Switch **"NEW"**
- RLP-4012BBSCLVD is a continuous duty 13.8 VDC output power supply
- 3 year warranty



#### DESCRIPTION

The RLP-4012-BBSCLVD is a Heavy Duty AC to DC Power Supply. All of the RLP-BBSCLVD comes with a power factor correction with metering voltage and amperage. All of the RLP-BBSCLVD come with three layers of protection against overload, over voltage, over temperature, and short circuit protection. This model also comes with a new manual battery disconnect switch and remote control with remote sense.

#### SPECIFICATIONS

Output Voltage .....	13.8 VDC
Output Voltage Tolerance .....	+/- 1 %
Output Amperage .....	40 Amps cont.
Maximum Power, continuous .....	600 Watts
Maximum Ripple and Noise .....	150 mV p-p max
Input Voltage, Switch Selectable .....	110-or 220 VAC
Input Frequency Range .....	47-63 Hz
Maximum AC Current .....	7 Amps/120 VAC; 4-5 Amps/240 VAC
Typical Efficiency .....	84 %
Max Inrush Current, single cycle .....	35 Amps
Short Circuit Protection .....	Fold back Limiting
Overload Protection (operates) .....	typical 110-120 %
Line Regulation .....	.50 mV
Load Regulation .....	100 mV (20-100 pct load)
Fan Control .....	Heat sink temp >140 F (60 C) = ON
Over Temperature .....	>195 F (90 C) auto output shutdown
Rise Time following ON .....	.50 mS
Hold Time following OFF .....	10 mS
Working Temperature Range .....	-20 + 60 C
Storage Temperature .....	-40 - 185 F (-40 - +85 C)
Withstand Voltage* .....	1.5 KV @ 10 ma (I/P-O/P, I/P-FG)/1 min
(Continued) .....	500 V @ 10 ma (O/P-FG)/1 min
Dimensions .....	3.5H x 19W x 13D inches, nominal
Weight .....	16 lbs, nominal

## **METER CIRCUITS**

The panel meter is switched to provide DC output voltage measurement and individual output load current measurement for each individual module.

When set to the VOLT position, the full scale reading is 30 volts.

When set to the AMP position, the full scale reading is 60 amps.

The meter and associated circuitry accuracy is 10 percent of full scale deflection. Since full scale is 60 amps, a 20 amp current can vary from 18 to 22 amps indicated. To prevent unnecessary output voltage drops, the meter circuits use the voltage drop of the black #12 AWG negative return to the module as a meter shunt. The #12 AWG wire provides a nominal 100 mV drop at 60 amps

The meter sensitivity for voltage measurement is 1000 ohms per volt.

## **BATTERY BACK UP & CHARGER**

Maximum Power, continuous .....	600 Watts
Auto-revert to Battery or Power Supply .....	provided by dual Shottky diode in OR configuration
Maximum Output Current in Battery Mode .....	75 Amps (limited by Shottky diode)
Maximum Charge Voltage .....	13.8 VDC
Maximum Recharge Rate .....	7 Amps with auto sensing of charge current
Charger Protection .....	Overload/voltage/temperature/reverse polarity protected
Dead Battery Protection .....	Short circuit protected with deep discharge start function
AC Input .....	90-130 / 180-260 VAC, 47-63 Hz, switch selected
Visual Indication .....	Bi color LED indication: Red = high rate charge, Green = Float charge

## **LOW VOLTAGE DISCONNECT with RELAY**

Maximum Interrupt Current / continuous current .....	75 Amps DC
Disconnect Voltage .....	11.5 VDC
Reconnect Voltage .....	12.5 VDC
Disconnect Delay .....	2 minutes @ less than preset disconnect voltage

## **INSTALLER NOTES**

**NOTE:** DO NOT block any of the cooling vents on the sides and always allow adequate ventilation by not installing the unit inside tightly closed spaces. Physical mounting position is not critical but the cooling vents must not be blocked.

**NOTE:** The outputs are **NOT** referenced to the chassis. **The Modular System can be used either positive or negative ground.**

## INSTALLATION BLOCK DIAGRAM

### RLP-4012-BBSCLVD Remote Control and DC-OK

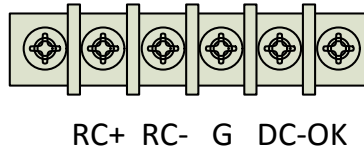

Between RC- and RC+	Output Status
Switch Closed or 0 – 0.8V	PSU OFF
Switch Open or 4 – 10V	PSU ON

Between DC-OK and GND (TTL Output)	Output Status
0 to 1 V or TTL LOW	PSU OFF
3.3 to 5.6 V or TTL HIGH	PSU ON

### RLP-BBSCLVD Wiring Layout

This system setup will provide continuous power to the load and maintain battery bank with smart charger while AC power is on. There is a seamless transfer of the load to the battery when the AC power goes off. The LVD will disconnect the battery if the voltage drops below 11.5 VDC. The battery reconnects once AC power is restored and voltage reaches 12.5 VDC.

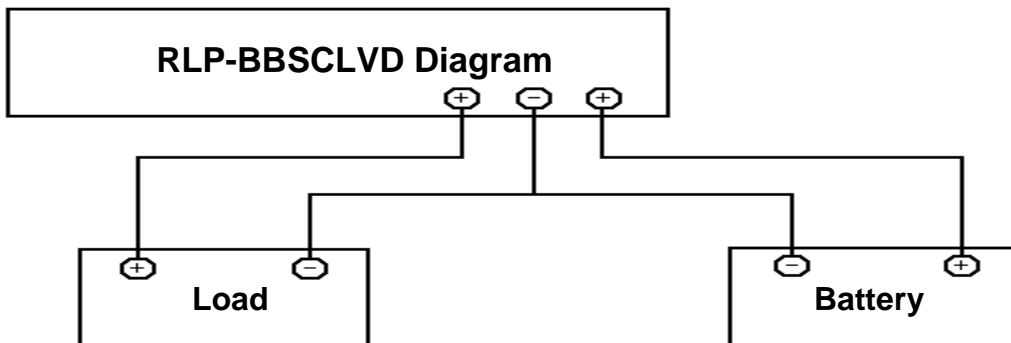

## **CONDUCTOR PRETREATMENT**

All kinds of copper conductors can be clamped without treatment. DO NOT solder tin stranded conductors. The solder yields and fractures under high pressure. The result is increased contact resistance and excessive temperature rise. Additionally, corrosion has been observed due to the fluxes. Notch fractures at the transition from the rigid tinned part to the flexible conductors are also possible. Ferrules can be used as a protection when wiring stranded conductors. Copper ferrules prevent the current transfer from being influenced by dissimilar metals and remove the risk of corrosion. Always use the correct tool to crimp the ferrule.

## **RECOMMENDED COPPER WIRE SIZE FOR CURRENT CAPACITY**

(Insulated Wire, Single Conductor in free air)

<b><u>Current Level in Amperes</u></b>	<b><u>Wire Size</u></b>
<7 AMPERES	20 AWG Up to 5 feet 18 AWG Up to 10 feet
14 AMPERES	18 AWG Up to 5 feet 16 AWG Up to 10 feet
20 AMPERES	16 AWG Up to 5 feet 14 AWG Up to 10 feet
30 AMPERES	14 AWG Up to 5 feet 12 AWG Up to 10 feet
40 AMPERES	12 AWG Up to 5 feet 10 AWG Up to 10 feet
50 AMPERES	10 AWG Up to 5 feet 8 AWG Up to 10 feet
70 AMPERES	8 AWG Up to 5 feet 6 AWG Up to 10 feet
100 AMPERES	6 AWG Up to 5 feet 4 AWG Up to 10 feet

## **LIMITED WARRANTY**

*DuraComm warrants to the initial end user, each power supply manufactured by DuraComm to be free from defects in material and workmanship, when in normal use and service for a period of three years from the date of purchase, from an authorized DuraComm dealer.*

*Should a product manufactured by DuraComm fail or malfunction due to manufacturing defect, or faulty component, DuraComm, at its option, will repair or replace the faulty product or parts thereof, which, after examination by DuraComm, prove to be defective or not operational according to specifications in effect at the time of sale to the initial end user. The product that is replaced or repaired under the provisions of this warranty, will be warranted for the remainder of the original warranty period, only, and will not extend into a new three year warranty period.*

*The limited warranty does not extend to any DuraComm product which has been subject to misuse, accidental damage, neglect, incorrect wiring not associated with manufacture, improper charging voltages, or any product which has had the serial number removed, altered, defaced, or changed in any way.*

*DuraComm reserves the right to change, alter, or improve the specifications of its products at any time, and by so doing, incurs no obligation to install or retrofit any such changes or improvements in or on products manufactured prior to inclusion of such changes.*

*DuraComm requires any product needing in or out of warranty service to be returned to DuraComm. All requests for warranty service must be accompanied by proof of purchase, such as bill of sale with purchase date identified. DuraComm is not responsible for any expenses or payments incurred for the removal of the product from its place of use, transportation or shipping expenses to the place of repair, or return expenses of a repaired or replacement product to its place of use.*

*The implied warranties which the law imposes on the sale of this product are expressly LIMITED, in duration, to the three (3) year time period specified herein. DuraComm will not be liable for damages, consequential or otherwise, resulting from the use and operation of this product, or from the breach of this LIMITED WARRANTY.*

*Some states do not allow limitations on the duration of the implied warranty or exclusions or limitations of incidental or consequential damages, so said limitations or exclusions may not apply to you. This warranty gives you specific legal rights which vary from state to state.*

*This warranty is given in lieu of all other warranties, whether expressed, implied, or by law. All other warranties, including WITHOUT LIMITATION, warranties of merchantability and fitness or suitability for a particular purpose, are specifically excluded. DuraComm reserves the right to change or modify its warranty and service programs without prior notice.*

## **DuraComm® Corporation**

*6655 Troost Avenue*

*Kansas City, MO 64131*

*Phone (816) 472-5544 Fax (816) 472-0959*

*www.duracomm.com*