



A Benny Lee Company

# PRODUCT USER GUIDE

## BMS-24-40

### 24-Volt Battery Management System

### Owners Guide

*(These instructions are intended for use by a technician familiar with electronic products)*

- 1 Rack unit high
- Up to 75 Amps max load
- Suggested battery capacity: 30 to 60 AH
- Smart Charging and Low Voltage Disconnect
- Front panel indicators for battery status and DC output
- 3 year warranty



#### **DESCRIPTION**

The Model BMS-24-40 is a complete battery management system for installations, which already have a primary power supply. Smart Charging with Low Voltage Disconnect maintains battery protection by preventing battery failures caused by over-charging or excessively deep discharging. Dual Schottky diodes provide smooth transfer to battery power and seamlessly auto-revert back to the main AC powered source.

The Smart Charger is designed to auto-charge and maintain Gelled electrolyte (Gel-Cell) and liquid electrolyte lead-acid 24 volt batteries from 30 to 60 Amp Hour. The charger is a constant current monitoring charger for the charging and maintenance of fixed location UPS, emergency lighting systems, and telecommunications battery backup systems.

The charger is protected against over loading, over-voltage, over-temperature, short circuit and reverse polarity by auto shut down. The charger auto-recovers after fault condition(s) are removed.

The Model BMS-24-40 incorporates an automatic Low Voltage Disconnect that monitors battery voltage and disconnects the load when the battery voltage drops below 21.5 VDC. The LVD has been adjusted and calibrated at the factory for correct voltage disconnect and re-connect. No adjustment is required.

The LVD is pre-set to disconnect the load at 21.5 VDC. However, to prevent premature or false disconnect when the battery voltage drops below the 21.5 volt threshold a 2 minute timer is started. If the battery recovers to above 21.5 volts, the timer resets and waits. The battery can and will recover if the system is a repeater or remote base station or similar equipment that has a varying demand that fluctuates from low to high current. The timed delay ensures the battery is not disconnected until necessary to prevent damage.

After the AC main power is restored and the battery is recharging, the LVD will reconnect the load when the battery voltage exceeds 25 volts.

#### **SPECIFICATIONS**

Operational DC Voltage .....	27.6 VDC, nominal
Maximum Current, continuous .....	75 Amps
Low Voltage Disconnect .....	21.5 VDC
Low Voltage Re-Connect .....	25 VDC
AC Input voltage range (switch selectable) .....	100-130 or 200-260 VAC
Max inrush current, single cycle .....	35 Amps
Input frequency range .....	47-63 Hz
Typical Efficiency .....	80%
Short Circuit protection .....	Foldback Limiting
Overload Protection (operates) .....	typical 105-150%
Over Temperature .....	>195 F (90 C) auto output shutdown
Working Temperature range .....	-4 - 140 F (-20 - +60 C)
Storage Temperature .....	-40 - 185 F (-40 - +85 C)
Size .....	1.75 in (one rack unit) h x 19 in w x 10 in d

Weight..... 6.5 lb, nominal

## **CHARGER SPECIFICATIONS**

Output Voltage, charger..... 27.6 VDC  
Maximum Charger Power, continuous..... 120 Watts  
Maximum Charger output current..... 4 Amps

## **INSTALLATION WARNING**

*The individual user should take care to determine, prior to use or installation, whether this device is suitable, adequate or safe for the use intended. Since individual applications are subject to great variation, DuraComm makes no representation or warranty as to the merchantability, suitability or fitness of these units for any specific application.*

**DO NOT** block any of the cooling vents on the sides and always allow adequate ventilation by not installing the unit inside tightly closed spaces. Physical mounting position is not critical but the cooling vents must not be blocked. Make certain the input voltage switch is set to the correct voltage **BEFORE** applying AC power.

**The power supply output voltage measured at the rear panel terminals should be set to 28 VDC using an accurate voltmeter. This is to compensate for the 0.3 volt drop of the diodes. If this voltage is not correct, charger miss-operation will result.**

Connect the battery positive to the red terminal labeled, "Battery Positive (+)".

Connect the load positive to the red terminal labeled, "Load Positive (+)".

Connect the power supply positive output to the red terminal labeled, "Power Supply Positive (+)".

Connect the power supply, battery and load negative outputs to the black terminal labeled, "Battery, Load & Power Supply Negative (-)".

**CAUTION:** Under no circumstances should more than 30 VDC be applied to the input. Permanent damage to the LVD will result.

Make certain the unit is OFF. Double check the color coded leads from the battery, load and power supply. Select the proper AC input voltage, 110-120 VAC **or** 220-240 VAC, **prior** to plugging the unit into the AC mains.

**L.E.D. STATUS INDICATORS** - There are two LED type status lights located on the BMS unit. The Smart Charger indicator is located to the right of the ON/OFF switch and the DC OUT indicator is to the left.

**DC OUT** – Flip the switch to the ON position and the DC OUT indicator should glow a steady green to indicate acceptable VDC output to the LOAD. If output to the load drops below safe level the LVD will disconnect and cause the DC OUT indicator to turn off.

**SMART CHARGER** - Red indicates high rate charging. If the battery is in a fully charged state the LED will change to green after a few minutes indicating a float charge rate. During the transition time from high rate to float rate a bicolor flash from the LED may be observed.

If the LED flashes green, turn OFF the unit and check your wiring and battery connections. The LED may also flash green when first connected to a fully charged battery. When monitoring a fully charged battery the LED will be green.

When charging series connected batteries identical batteries must be used.

This completes the installation. Failures require investigation as to cause and/or repair of the unit.

**THERE ARE NO USER SERVICEABLE PARTS INSIDE. SERVICE AND REPAIR MUST BE REFERRED TO QUALIFIED FACTORY PERSONNEL.**

## INSTALLATION BLOCK DIAGRAM

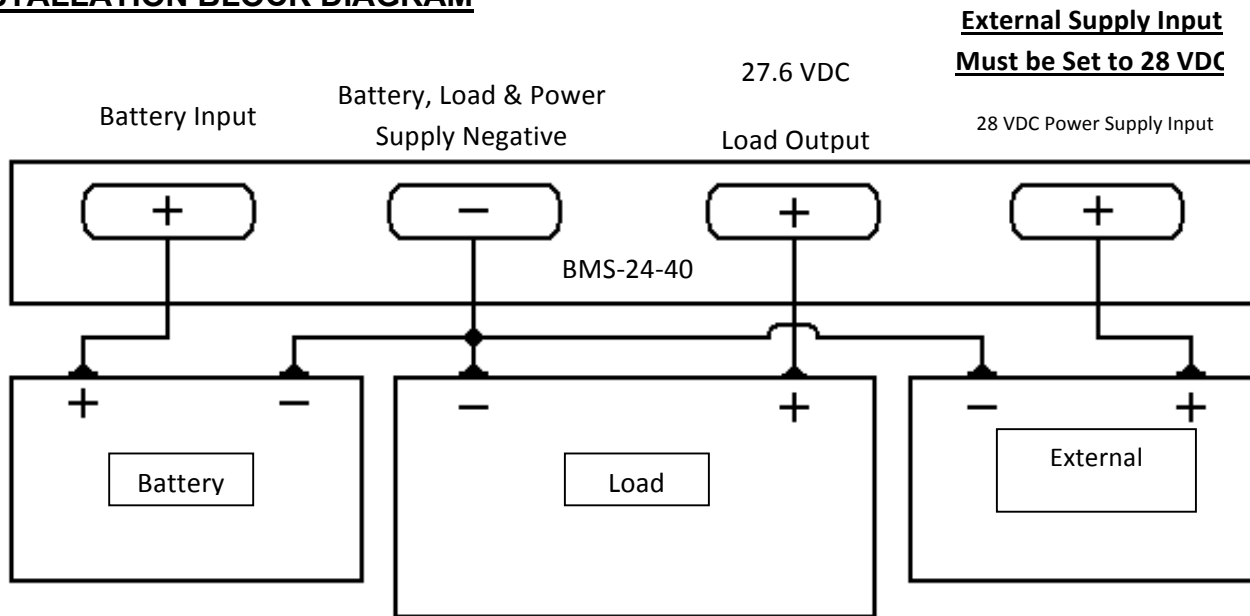

## RECOMMENDED COPPER WIRE SIZE FOR CURRENT CAPACITY

*(Insulated Wire, Single Conductor in free air)*

<u>Current Level in Amperes</u>	<u>Wire Size</u>
<7 AMPERES	20 AWG Up to 5 feet 18 AWG Up to 10 feet
14 AMPERES	18 AWG Up to 5 feet 16 AWG Up to 10 feet
20 AMPERES	16 AWG Up to 5 feet 14 AWG Up to 10 feet
30 AMPERES	14 AWG Up to 5 feet 12 AWG Up to 10 feet
40 AMPERES	12 AWG Up to 5 feet 10 AWG Up to 10 feet
50 AMPERES	10 AWG Up to 5 feet 8 AWG Up to 10 feet
70 AMPERES	8 AWG Up to 5 feet 6 AWG Up to 10 feet
100 AMPERES	6 AWG Up to 5 feet 4 AWG Up to 10 feet

## **LIMITED WARRANTY**

*DuraComm warrants to the initial end user, each power supply manufactured by DuraComm to be free from defects in material and workmanship, when in normal use and service for a period of three year from the date of purchase, from an authorized DuraComm dealer.*

*Should a product manufactured by DuraComm fail or malfunction due to manufacturing defect, or faulty component, DuraComm, at its option, will repair or replace the faulty product or parts thereof, which, after examination by DuraComm, prove to be defective or not operational according to specifications in effect at the time of sale to the initial end user. The product that is replaced or repaired under the provisions of this warranty, will be warranted for the remainder of the original warranty period, only, and will not extend into a new three year warranty period.*

*The limited warranty does not extend to any DuraComm product which has been subject to misuse, accidental damage, neglect, incorrect wiring not associated with manufacture, improper charging voltages, or any product which has had the serial number removed, altered, defaced, or changed in any way.*

*DuraComm reserves the right to change, alter, or improve the specifications of its products at any time, and by so doing, incurs no obligation to install or retrofit any such changes or improvements in or on products manufactured prior to inclusion of such changes.*

*DuraComm requires any product needing in or out of warranty service to be returned to DuraComm. All requests for warranty service must be accompanied by proof of purchase, such as bill of sale with purchase date identified. DuraComm is not responsible for any expenses or payments incurred for the removal of the product from its place of use, transportation or shipping expenses to the place of repair, or return expenses of a repaired or replacement product to its place of use.*

*The implied warranties which the law imposes on the sale of this product are expressly LIMITED, in duration, to the three (3) year time period specified herein. DuraComm will not be liable for damages, consequential or otherwise, resulting from the use and operation of this product, or from the breach of this LIMITED WARRANTY.*

*Some states do not allow limitations on the duration of the implied warranty or exclusions or limitations of incidental or consequential damages, so said limitations or exclusions may not apply to you. This warranty gives you specific legal rights which vary from state to state.*

*This warranty is given in lieu of all other warranties, whether expressed, implied, or by law. All other warranties, including WITHOUT LIMITATION, warranties of merchantability and fitness or suitability for a particular purpose, are specifically excluded. DuraComm reserves the right to change or modify its warranty and service programs without prior notice.*

## **DuraComm® Corporation**

6655 Troost Avenue  
Kansas City, MO 64131  
Phone (816) 472-5544 Fax (816) 472-0959  
[www.duracomm.com](http://www.duracomm.com)